

# Fixed-Wing UAV Wing Structure: A Study on Design and Optimization Techniques

PADMA RAO<sup>1</sup>, MOHD FIRASATH ALI<sup>2</sup>, Dr. SYED MUJAHED HUSSAINI<sup>3</sup>

**Department of Mech**

**Nawab Shah Alam Khan College of Engineering and Technology (NSAKCET)**

## Abstract

One of the most crucial components of any airplane, the wing, must always be meticulously designed to maximize lift while decreasing drag and weight. The general design of any contemporary fixed-wing UAV must constantly prioritize increasing the cruise duration. It is desirable to design a wing that is as light as possible while yet meeting the needs of working conditions. In this study, we compared several wing designs and settled on a beam-type wing based on the work circumstances. After that, we optimized and designed the wing in great detail to make it lighter. Finally, we sketch up the 3D model for possible realistic manufacturing.

## Keywords

Wing Structure, Optimization, 3D Model Design

## 1. Introduction

The wing is an essential component of every airplane. One kind of fin that may generate lift and propel an object through the air or another fluid is the wing. The entire performance of the airplane is heavily dependent on the quality of the wing design [1].

Developing the needs of the contract work or meeting tactical technical criteria is the responsibility of structural design. This involves creating a unique wing structure. The airfoil arrangement, the relative placement of the wing body, the internal location, and the plane form of the wing surface are all part of this. There are a few common structural shapes for wings, including

beam, single block, multi-ventral plate, and hybrid. Combinations or developments of these wing structures are other possible options [2].

Over the last hundred years, the wing's design has evolved. Take the wing of a contemporary aeroplane like a Boeing 787 as an example; it looks quite different from the Wright plane's (Figure 1). The amount, form, dimensions, and composition of



**Figure 1.** The aircraft designed by Wright Brother.



**Figure 2.** Boeing 787.

the lift surfaces will affect the performance of the aircraft.

Since 1930s, NASA and its predecessor, NACA, have been at the forefront of the design of the wing. Their development of the basic wing shapes has become the first choice for the major aero-nautical manufacturer. They are playing a critical role to nowadays air travel.

For this project, the task is to design and optimize a wing based on the design task book. The goal is to design a wing with the lightest weight that can satisfy strength, stiffness and life requirements. For an aircraft, the wing structure accounts for 25% - 50% of the aircraft body mass, which accounts for

8% - 15% of the whole aircraft quality. Also, the wing occupies 30% - 50% of the total air resistance of the aircraft. According to these statistics, a suitable wing is crucial to the performance of the whole aircraft [3].

As mentioned, the goal of designing a wing is to minimize the weight of the wing under the premise that the wing strength meets the requirements of deflection, stiffness and strength. In this project, we involve optimization, modeling, finite element analysis and so on, which is helpful to our understanding of air-

craft design profession and occupation.

The traditional wing design experience is very abundant. The founder of the wing design is mainly the American NASA and its predecessor NACA. The four digits and the five digits airfoil library that developed by NASA has a very important place in the aviation history. Many aircraft design and airfoil are selected directly from the airfoil.

When it comes into twenty-first Century, the design of the aircraft involves the support of computer. Not only the structural strength of the aircraft was guaranteed, but also the reliability and weight of the aircraft are strictly controlled [4] [5] [6] [7] [8].

The corresponding intelligent materials are also being developed to seek the rapid response of aircraft to aeroelastic changes, or the use of variable wings to study the form of aircraft wing damage.

In a word, the aircraft wing is a vital component of the aircraft, which has great influence on the performance of the aircraft.

This wing design requires the design of a small wing with a chord length of 200 mm, a ratio of 5 to a chord, and a sweep angle of 30 degrees.

The load of the wing is set according to the wing load and the wing area of the Cessna 152 small aircraft. The wing is subjected to lift 100 N and resistance 50 N. The deflection of the wing is defined according to the

relative deflection of 0.08, and the final allowable deflection is 30 mm.

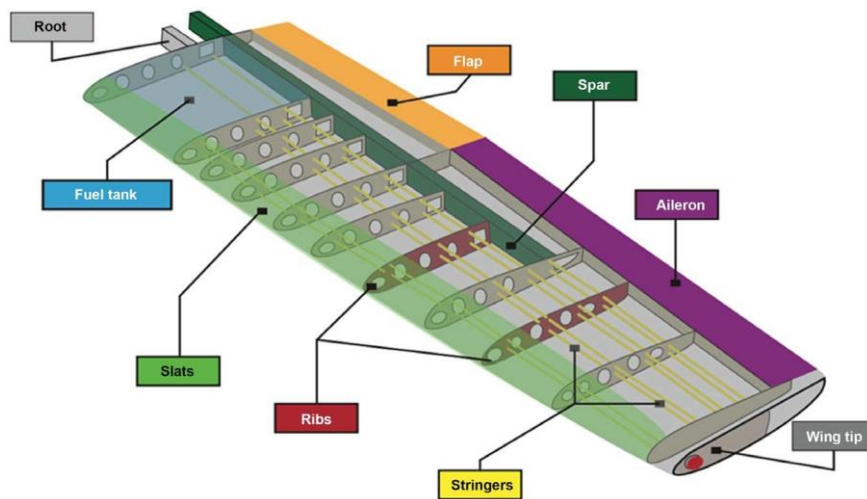
The allowable stress of the wing is divided by the ultimate stress of the material by the safety factor, in which the material performance is like the table and the safety factor is 1.5. At this time, the allowable stress is 270 Mpa

### Wing Structure

According to the task requirements, we plan to design a straight beam wing. The structure is shown below in **Figure 3**.

A straight beam wing is mainly consisted of skin, wing rib and wing beam. Skin forms a streamlined outer surface of the wing that take part in the airframe's force. In order to ensure the smoothness of the surface, the skin should have sufficient lateral bending stiffness. The skin can be combined with the stringer to form an integral panel to bear normal stress. The function of wing rib is to form the shape of the wing profile. It is connected to the truss and skin and provides vertical support to the truss and skin in the stiffness of its own plane. Wing beam is a simple load bearing structure that can support shear force  $Q$  and bending moment  $M$  [9]

In this work the process to design the wing structure is: 1) Select the airfoil



**Figure 3.** Structure of a straight beam wing [4].

shape from the airfoil library (NACA). 2) Choose the most efficient wing structure according to the

conditions. 3) Design the rib on the wing structure according to the airfoil shape. 4) Design other

parts in the wing structure. 5) Optimize the whole structure to the wing's weight.

## 2. Design Process

Wing design includes shape design and structural design. The shape of the wing is designed according to the tactical, technical and performance requirements of the aircraft, and the main geometric parameters of the wing are determined. The wing structural design is according to the basis provided by the aircraft overall design stage (including the shape design), to design a specific wing structure that can meet all the requirements. Specifically, the design process of the wing is that according to the original basis, choose the force form of the wing reasonably, arrange the main force components of the wing, determine the dimensions of the longitudinal components along the sections, and design the main force components.

The original basis of wing design is shown in **Figure 4**.

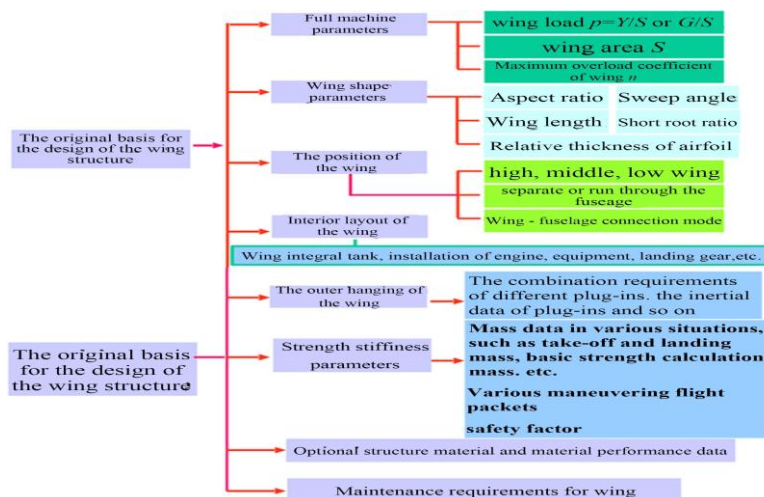
**Figure 4.** The original basis of wing design.

of structural strength and stiffness. 7) Draw production drawings. 8) Calculate the fatigue life and inspection period.

### Different Types of Wings

In modern aircraft design, wing structure must be considered in the overall stage. So that we choose the type of wing

There are two steps for wing structure design: proofing design and detailed design. Proofing design include the internal arrangement of the wing, the design of the separation plane, the selection of the structural type, the arrangement of the main force components, the drawing of the airfoil theoretical map and the proof drawing. Detailed design including the wing parts and components design. That is a process from parts, components to complete set of production drawings. And finish the calculation of total strength, stiffness and life of the wing. The detailed steps are: 1) Calculation of external load and internal force. 2) Internal arrangement, determine the structure type, design separation plane, docking mode, arrange the main force components, draw the proofing map. 3) Design calculation and design the strength of each component. 4) Draw the theoretical map of the wing. 5) Design of wing structural elements. 6) Calculation



carefully. After the overall scheme is determined, the structural type of the components and the layout of the main load elements are basically determined, and no modification is allowed in the structural design.

#### **Beam Type**

There are strong wing beams in the longitudinal direction, thin skins and weak girders. The edge section of beams is much larger than that of long truss sections. Its advantages are that the structure is simple, the opening on the skin is convenient, the opening has little influence on the bending capacity of the structure, and the connection is simple, and the docking point is small. The disadvantages are that the skin cannot play the role of bending, material utilization is not sufficient, the skin is easy to lose stability, influence the quality of air flow, increase resistance, and easily lead to early fatigue damage and low survivability.

#### **Single Block Type**

For this type, the stringer is longer and stronger, the skin is thicker, and the wingrib is denser. The section area of the general beam bar is usually not large, and sometimes only the longitudinal wall is arranged.

The advantage of this type of wing is that the skin deformation is small, and the air flow quality is high when aerodynamic load is applied. The material is dispersed to the outer edge, and the bending resistance, torsional strength and stiffness are all improved. The safety and reliability are good. The disadvantage is that the structure is complex and sensitive to the opening and the connection is complex because it has more joint points with the middle wing or the fuselage.

#### **Multi-Ventral-Plate-Type**

This type of wing is equipped with more longitudinal walls with thicker skin. The thick skin bears all the bending moments. The advantage is that the flexural material is distributed on the upper and lower edges of the section, with high structural efficiency, large local stiffness and overall stiffness. Also, this kind of wing have high dispersion of the force, good safety damage and high survivability. The only disadvantage is that it is not suitable for large opening and there are a large number of connection points with the fuselage.

The main difference between the three types of wing type of wing is that the dispersion of the area of the positive stress element caused by bending moment is different, so when the total area of the element is at the same time, the center distance of the latter is higher, the structure efficiency may be higher, and the weight may be lighter. Further analysis is needed for the specific situation.

Here we choose the beam type for this mission. For this wing we begin from the layout of the main force components, which includes mode, quantity and position. For main force components, they include

beams, walls, stiffeners, common ribs, stringers, etc. Some examples of planes and their wing type data is shown below in and effective height ratio are considered purely from the structural point of view. In fact, the choice of structural load types is largely influenced by many factors in the overall layout of aircraft and needs comprehensive measurement. The first aspect is about internal layout of wing, such as retractable landing gear, large openings, etc. The second aspect is the relative position of the wing and the fuselage, as well as the interior of the fuselage. The third aspect is the geometric parameters of the wing, such as swept wing, delta wing, etc.

The layout of the main force components of the wing includes quantity and location of the main force components of the wing. The main force components are beams, walls, stiffeners, ordinary ribs, stringers and so on. The principle of the layout of the main force components is to ensure the bending, shear and torsion caused by aerodynamic load can be transmitted to the fuselage smoothly and reliably. At the point of concentrated force and concentrated torque, the corresponding components (reinforced rib, auxiliary short beam, etc.) should be arranged. The concentrated force is diffused; the distributed force after diffusion is transmitted to the stress box section of the wing structure, and then the load is transmitted to the fuselage at the base of the wing. Generally, the more direct the force is, the lighter the weight of the structure is. The layout of reinforced members should be made comprehensively to reduce weight.

Here we choose the beam type for this mission. For this wing we begin from the layout of the main force components, which includes mode, quantity and position. For main force components, they include beams, walls, stiffeners, common ribs, stringers, etc.

#### **Design Methods**

This design relies on finite element software Ansys, COMSOL as well as graphics software SolidWorks, Catia and Inventor. We use the finite element models to analyze distribution of stress and strain, and then optimize the design.

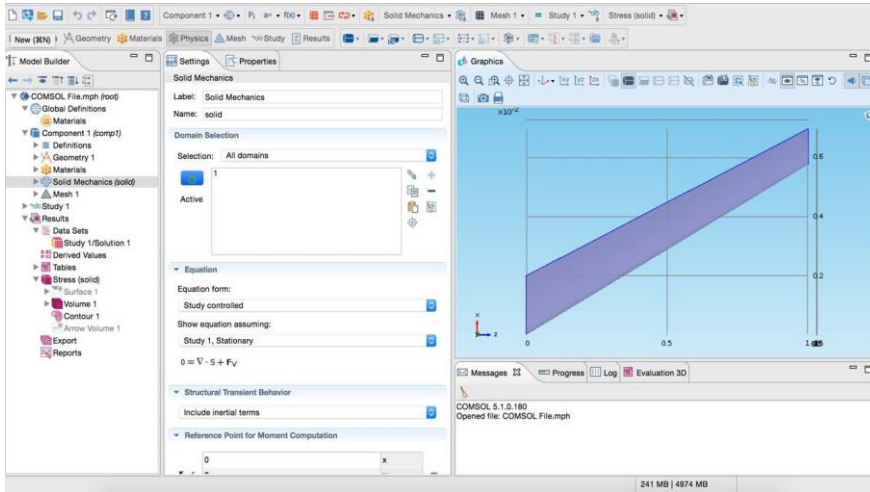
The design steps are as follows:

COMSOL Multiphysics + SolidWorks. Because the modeling of COMSOL is relatively simple, the interface is friendly, and the results are more content. Therefore, the initial analysis of the use of COMSOL can let us have an intuitive understanding of the overall distribution of the wing load. Then we can determine the position of the wing beam and the position of the wing ribs as well as quantities of the wing ribs (**Figure 5 & Figure 6**).

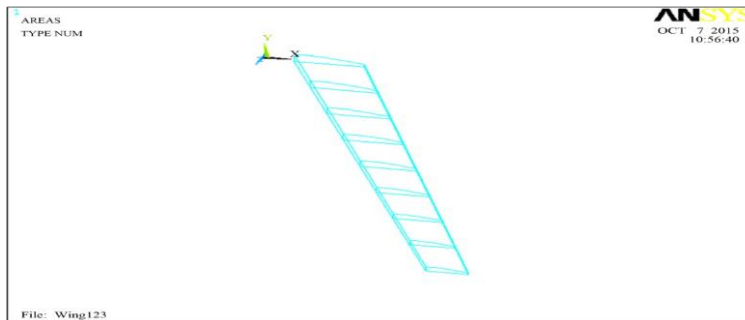
Ansys + Inventor. The position of the wing beam and the web is determined by the preliminary results.

After that we draw the wing structure with In-ventor, and then we input that to Ansys (**Figure 7**). According to the design re-quirements, we apply grid and loading to the model properly. The Shell unit and Beam unit of Ansys are used to cover the plane of the Inventor

(**Figure 7**), and the optimization design is carried out for the body of the wing. The object in the optimization model is to make the volume of the wing smallest. Under the cor-responding constraints, the weight of the wing is also the lightest.

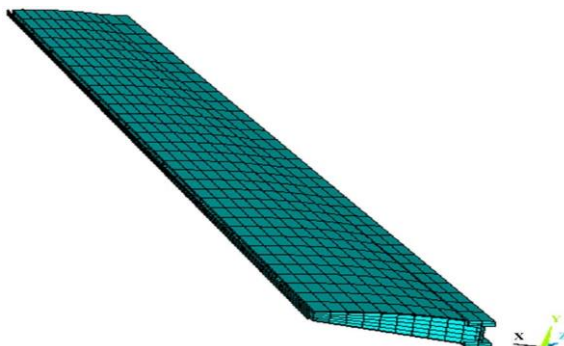


**Figure 5.** Settings of COMSOL model.



**Figure 6.** Model outline in Ansys.

**Figure 7.** Mesh of the model in Ansys.



Catia. After the structural parameters of each part of the wing are determined. We use Catia to draw the parts. The drawings can be produced directly if necessary.

**Results and Discussions**

**COMSOL Multiphysics Results**

In COMSOL, we apply lift and drag force to certain points according to design requirements. After calculation with the element model, we observe the stress and strain distribution of the wing. The results show that the maximum strain of the wing is concentrated on the 1/4 string strength. The strain on the root of the wing is distorted and complex (**Figures**

**8-10**).

As a result, the following design can be obtained:

The beam type wing structure is adopted, and the beam is on the 1/4 stringlength.

In the real wing structure, there need to be flapped and aileron, so the webis at the 85% string length.

Because the wing is small, the skin can be stable without using or using lesstrusses.

**Anslys Results Analysis**

Set the initial parameters to optimize the wing. The parameters are set as shownin the form (**Table 1 & 2**).

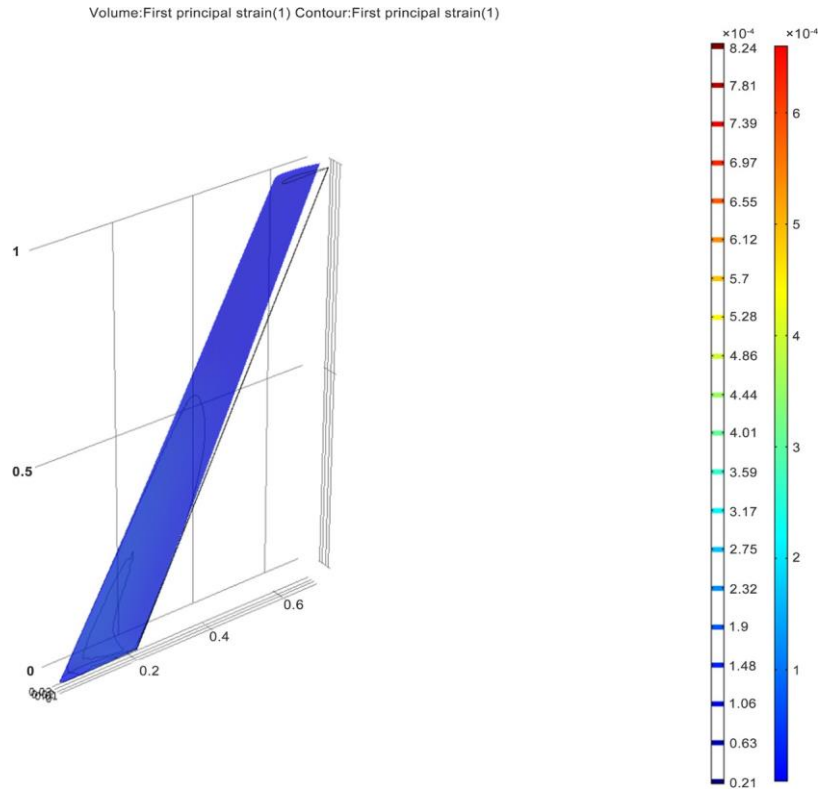
The results are shown in the figures (**Figures 11-16**).

**Table 1.** Parameters and notations.

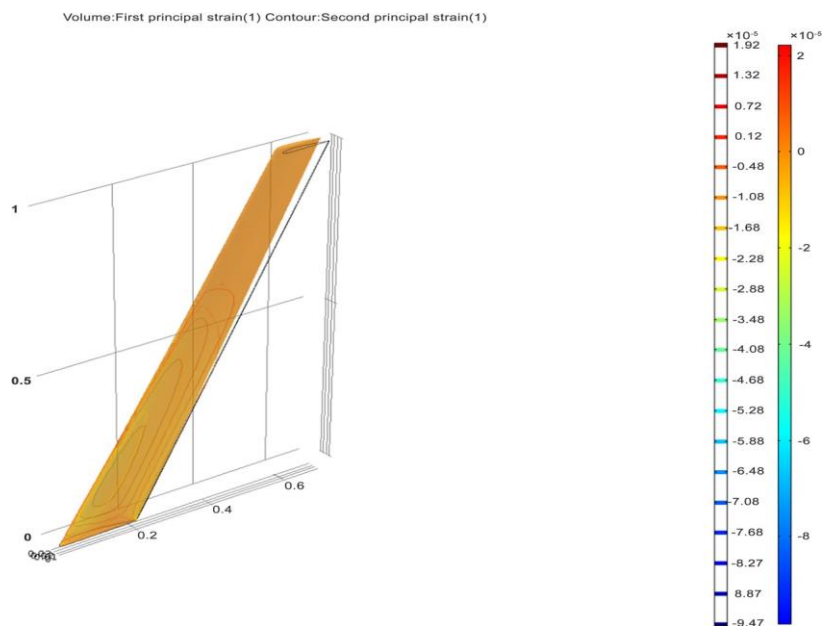
B	Trusses width
H	Trusses height
T1	Thickness of web
T2	Thickness of beam web
T3	Wing rib thickness
TS	Thickness of skin

**Table 2.** Optimization results and range.

Parameter symbol	Parameter name	Optimization results	Optimization range
<b>B</b>	Width of trusses	18.86 mm	5 - 20 mm
<b>H</b>	Height of trusses	5.00 mm	2 - 10 mm
<b>T1</b>	Thickness of web	6.62 mm	5 - 10 mm
<b>T2</b>	Beam web thickness	5.41 mm	5 - 10 mm
<b>T3</b>	Wing rib thickness	1.21 mm	0.5 - 3 mmm
<b>TS</b>	Thickness of skin	2.23 mm	0.5 - 5 mm
<b>DMAX</b>	Maximum pressure	86 MPa	less than 270 MPa
<b>DY</b>	Maximum deflection	30.15 mm	less than 30 mm



**Figure 8.** First principle strain cloud map.



**Figure 9.** Second principle strain cloud map.

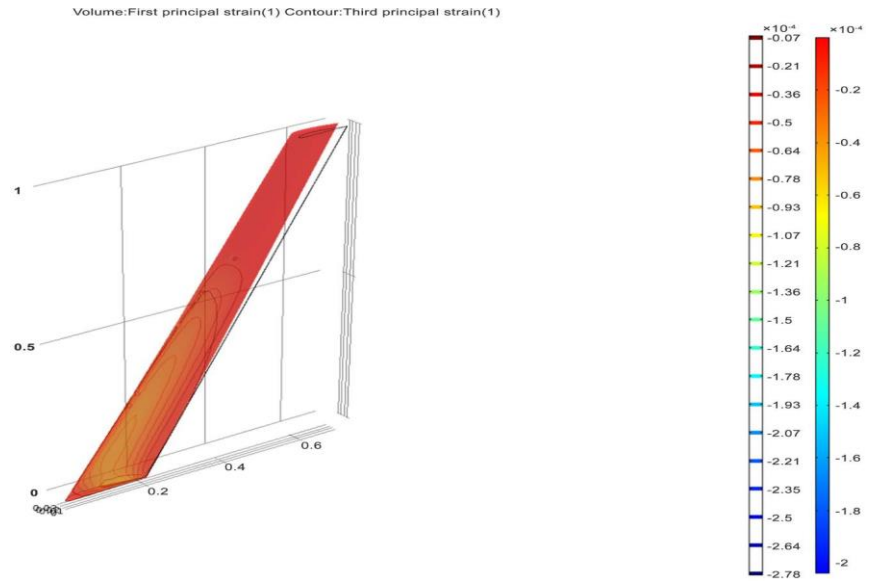


Figure 10. Third principle strain cloud map.

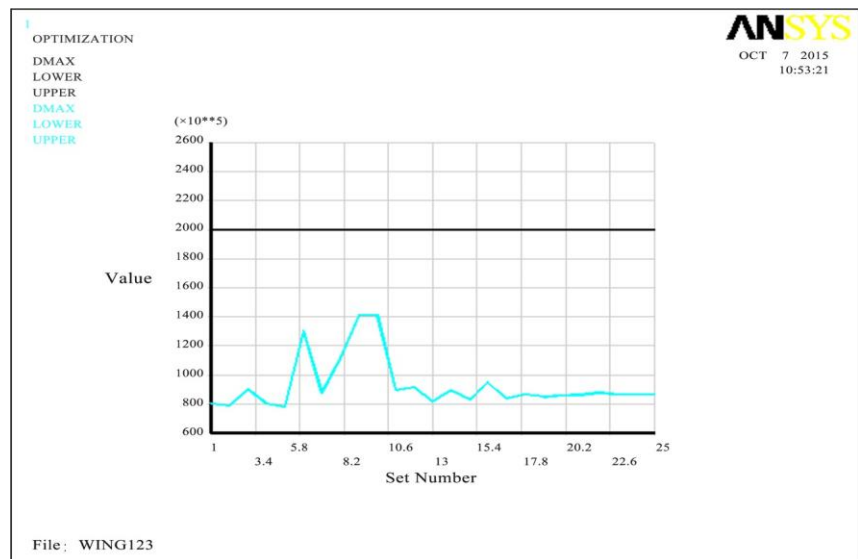
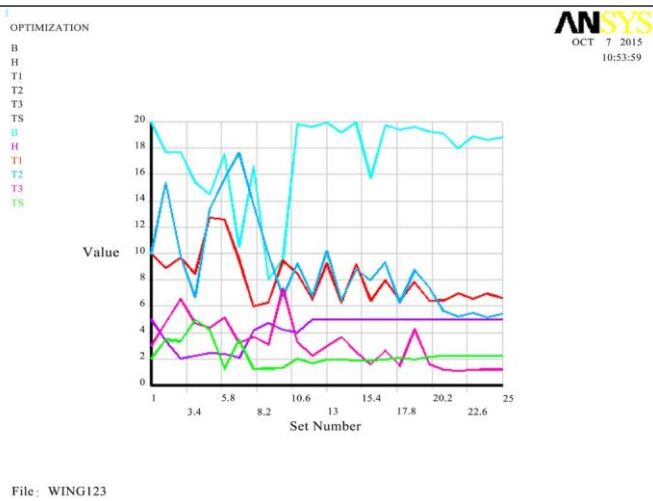
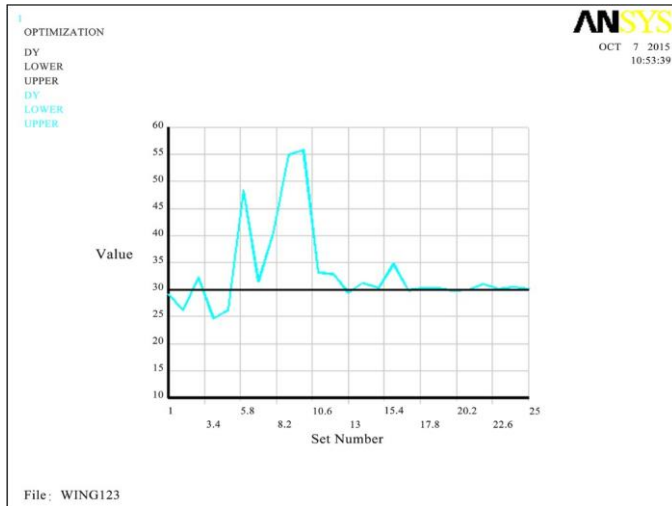


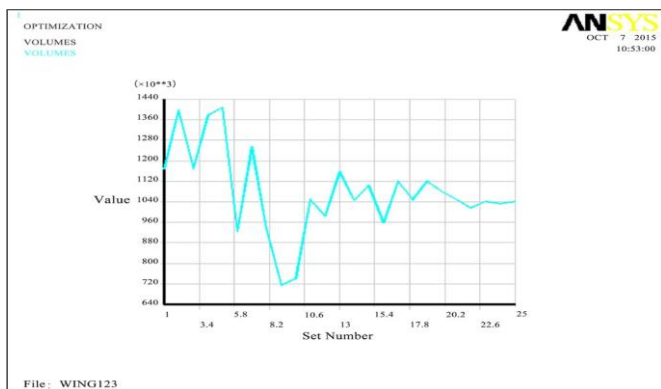
Figure 11. Stress change during optimization.

From the Ansys optimization results, we can see that all the optimization parameters and the optimization targets are convergent and meet the requirements.

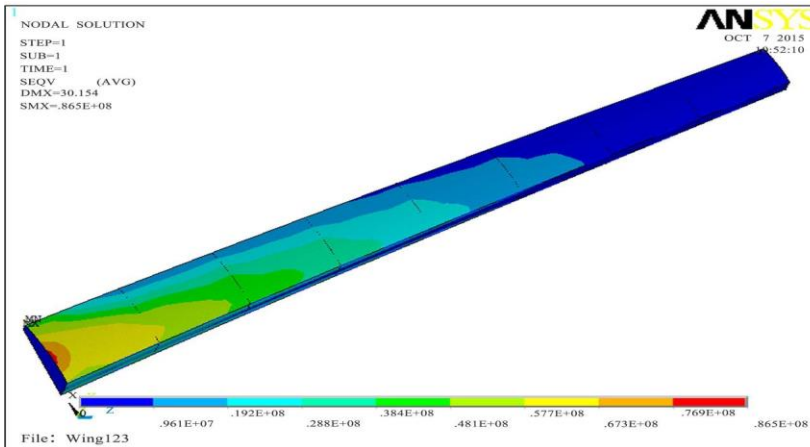
**Figure 12.** Deflection change during optimization.



**Figure 13.** Geometric parameter change during optimization.

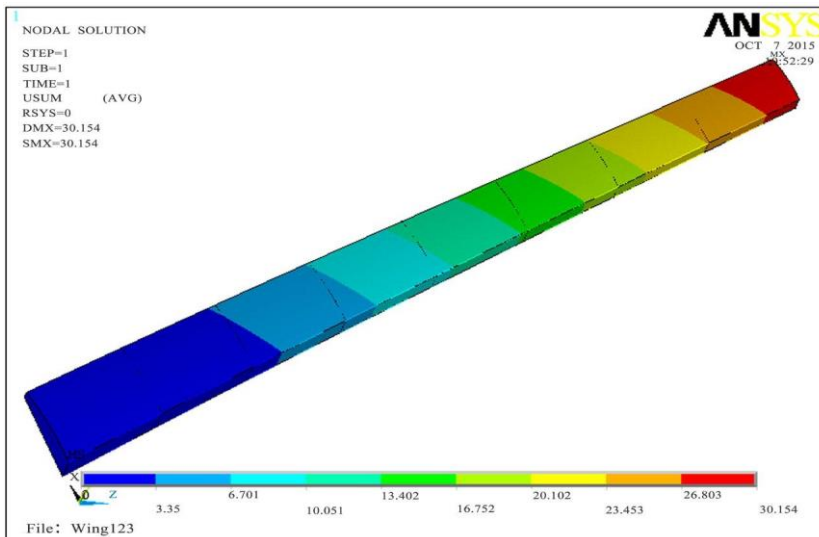


**Figure 14.** Volume change during optimization.



**Figure 15.** Stress cloud map.

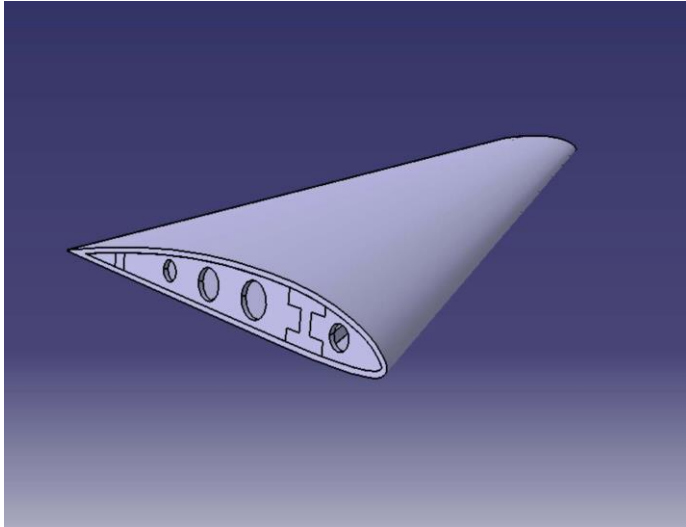
**Figure 16.** Strain cloud map.



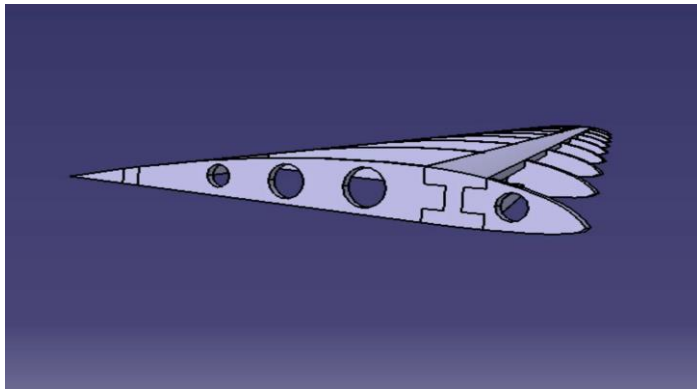
The stress, the strain cloud graph is reasonable, the optimization results are effective for the volume reduction and optimization [10] [11] [12].

### 2.1. CATIA Modeling

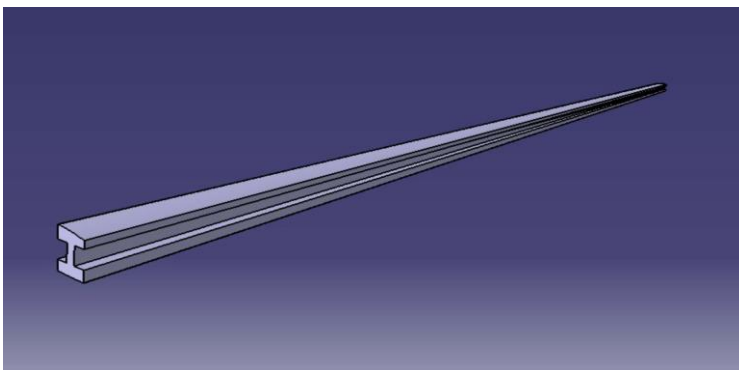
Wing beams, wing ribs and web plates are used as skeleton support. Because the wings are smaller, the upper and lower edges of the wing and web are repaired according to the skin to ensure that the aerodynamic shape of the wing is smooth, and the wing can play its due role (Figures 17-19).



**Figure 17.** Overall wing structure form.



**Figure 18.** Wing skeleton.



**Figure 19.** Wing beam.

### 3. Conclusion

Various wing types, including beam-type, single-block-type, and multi-ventral-plate-type, are compared in this study based on the work circumstances, such as a 100 Newton lift force and 150 Newton drag force. The beam-type wing was our final decision. Beam, rib, skin, and web were next designed in detail. We improved the wing to lower its weight after the structural design. Finally, in order to facilitate realistic manufacture, we create a 3D model of the components using Catia. We have completed the design and optimization for the fixed-wing UAV.

examples of both theoretical analysis and engineering applications. Press Machine in China.

The advanced use of ANSYS Workbench in structural engineering was discussed in Liu's (2015) work. Press of China Water and Power.

"ANSYS Numerical Analysis of Engineering Structure" (Wang, X.M., 2007). Press of China Communications.

### References

: [1] <https://en.wikipedia.org/wiki/Wing>

The second edition of Aircraft Structure Science was published by Beihang University Press in 2010 by Li, Z.N. According to Raymer (2012), aircraft design is approached conceptually. Version 15. Here is the link to the article: <https://doi.org/10.2514/4.869112>.

The authors of the 1978 paper "Wing Design by Numerical Optimization" are Hicks and Henne.

Publication: Journal of Aircraft, Volume 15, Pages 407–412, DOI: 10.2514/3.58379

By 2009, Young, Walker, Bomphrey, Taylor, and Thomas had collaborated on a scientific paper. Aerodynamic Function and Flight Efficiency are Improved by Studying Insect Wing Design and Deformation. The article is published in Science, volume 325, pages 1549-1552. URL: <https://doi.org/10.1126/science.1175928>

[6] Optimisation with Variable-fidelity Models Applied to Wing Design by Alexandrov, Lewis, Gumbert, Green, and Newman (2000). <https://doi.org/10.2514/6.2000-841>. 38th Aerospace Sciences Meeting and Exhibit, 841.

A. Vicini and D. Quagliarella, "Hybrid Optimization Strategies for Airfoils and Wings," 1999. <https://doi.org/10.2514/2.764> AIAA Journal, 37, 634-641.

Grades K-12 from the NASA Wing Design Report 8.

[9] Zeng, Z.P. (2005) Flight Dynamics of Aeronautical Aircraft. Press of Beihang University.

According to Zhang (2013), ANSYS 14.0 provides